

1. DESCRIPTION

The BOB1025 is a StudioHub™ breakout box for AudioScience audio adapters. It can be operated as either an analog breakout (4 stereo in and 8 stereo out) or AES/EBU digital breakout (4 stereo in, 6 stereo out and sync in/out).

All I/O is balanced on RJ-45 connectors using the StudioHub protocol. Connections to the audio adapter are via a 50pin high-density SCSI type connector for analog and a 26pin high-density connector for digital (AES/EBU).

The BOB1025 is 1RU; 19" W x 5.5" D x 1.75" H (482.6 mm W x mm 139.7 D x NN mm 44.5 H).

AudioScience cards that are supported include the ASI5500/5600 series, ASI6000 series and the ASI4300 series.



NOTE: The BOB1025 Can be operated in Analog OR Digital (AES/EBU) mode, but not both at the same time

2. CONFIGURATIONS

2.1 Analog Mode

In this mode, one BOB1025 supports 4 stereo inputs and 8 stereo outputs. Cable CBL1006 is needed when connecting to an ASI6000 or ASI5500/5600 series card and CBL1005 when connecting to an ASI4300 series card.

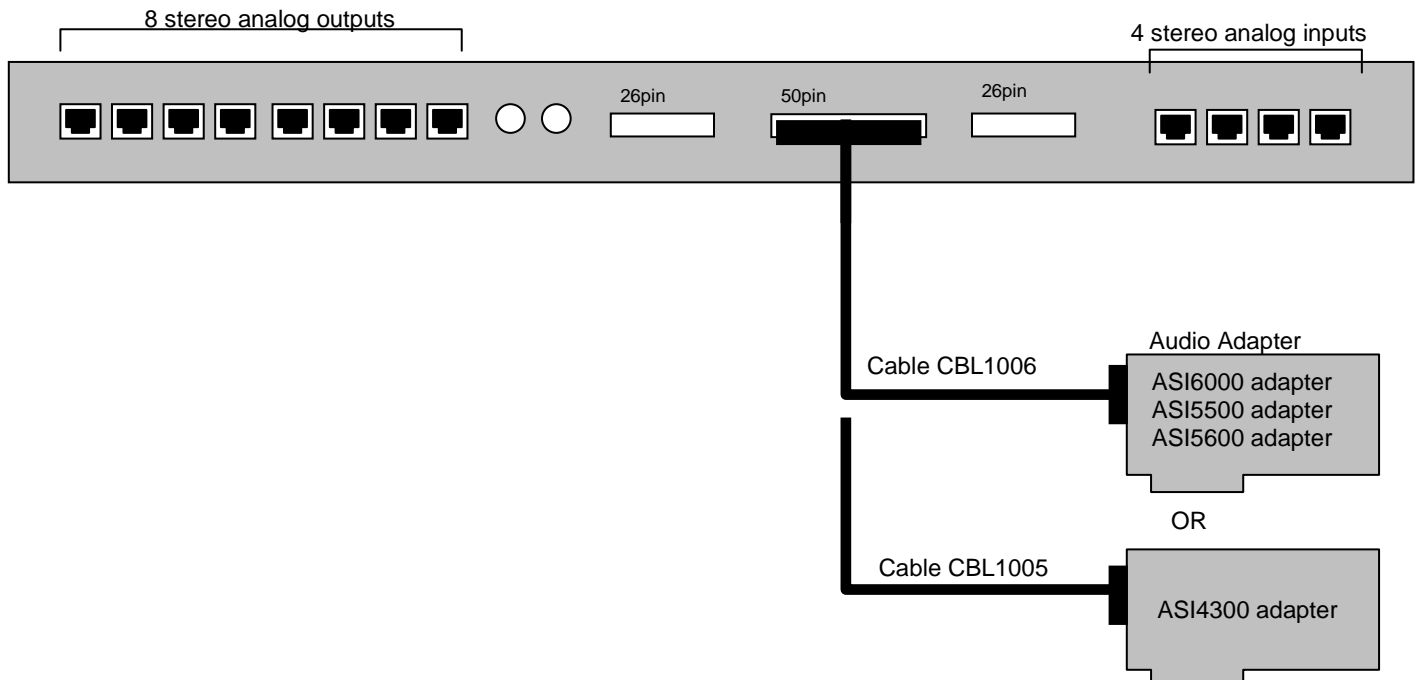

2.3 Digital Mode

In this mode, one BOB1025 supports 4 AES/EBU stereo inputs, 6 AES/EBU stereo outputs, AES/EBU sync in and word clock in. Cable CBL1102 is needed when connecting to an ASI5500/5600 or 6000 series card.

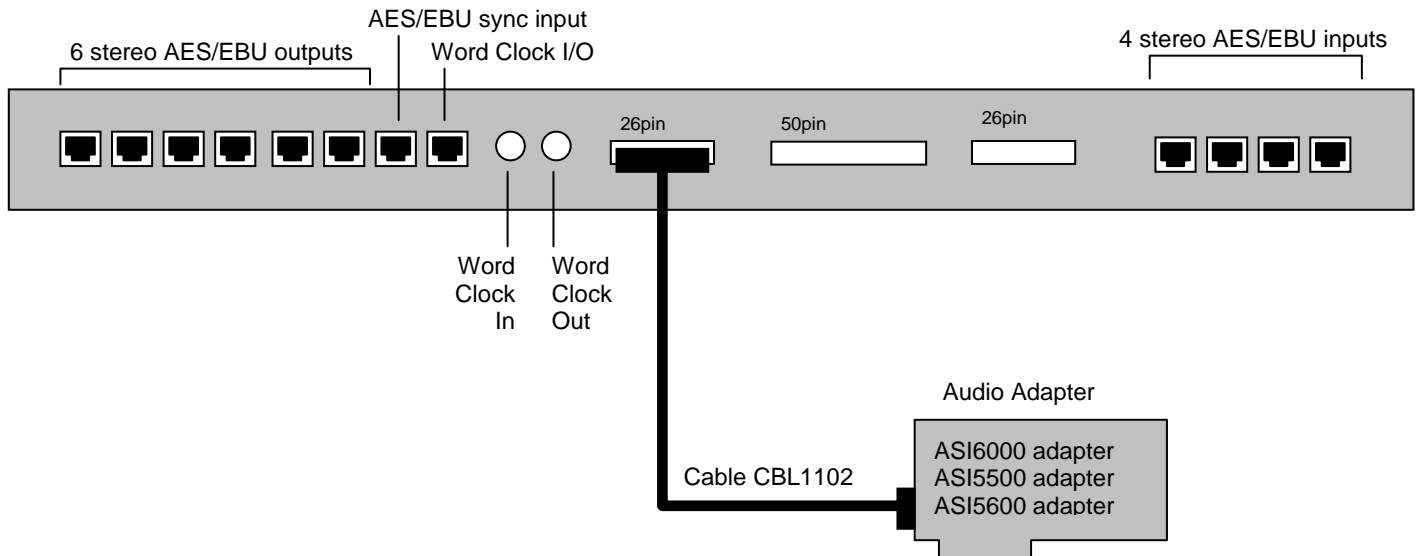

NOTE: On ASI6518 or ASI6618 sound cards, AES inputs 3 and 4 can be assigned as outputs 7 and 8. This allows one BOB1025 to be used; it will then have 8 AES/EBU 'outputs'. Please refer to the ASI6518/ASI6618 datasheet for further information on how to set this up.

<end>