



NBC-255-P IP Camera



- ▶ **Complete network video surveillance system inside a compact camera**
- ▶ **Progressive scan for sharp images of moving objects**
- ▶ **Dual-streaming: H.264 and M-JPEG**
- ▶ **Removable SD/SDHC card offers days of storage inside camera**
- ▶ **PC surveillance software supports multiple camera monitoring**
- ▶ **Two-way audio and audio alarm**
- ▶ **Power over Ethernet (IEEE 802.3af compliant)**

The Bosch NBC-255-P IP camera is a ready-to-use, complete network video surveillance system inside a compact camera. This camera brings Bosch's high-performance technology into the realm of small office and retail businesses by offering a cost-effective solution for a broad range of applications.

To use the camera as a stand-alone video surveillance system, simply take it out of the box, plug it in, start it and walk away – it's already recording. In this mode, no additional equipment is required.

For medium-to-large-scale or growing systems, the NBC-255-P IP camera easily integrates with the Bosch Divar XF Hybrid H.264 recorder. It uses H.264 compression technology to give you clear images while reducing bandwidth and storage by up to 30%.

Functions

Best-in-class image performance

The Bosch NBC-255-P IP camera delivers the clearest images and most accurate colors within its class. Progressive scan ensures moving objects are always sharp.

Dual streaming video

Dual streaming allows a data stream to be encoded simultaneously according to two different, individually customized settings. Two types of streams can serve different purposes. For example, use H.264 stream for local recording and viewing, and the M-JPEG stream to provide compatibility with legacy DVRs.

Efficient recording

A removable SD/SDHC card offers edge recording inside the NBC-255-P IP camera. This SD card not only saves network bandwidth but also reduces the requirement for a high-capacity hard disk or DVR. When used with an SD card, the NBC-255-P IP camera is a complete self-contained surveillance system without the need for additional equipment.

The NBC-255-P IP camera can also be used with an iSCSI server connected via the network to store long-term recordings.

PC surveillance software

The bundled PC surveillance software offers a user-friendly interface to support easy installation and configuration. A wizard allows the configuration of multiple cameras simultaneously using an auto detection device. Multiple cameras can be monitored in one screen and video clips on SD card can be archived and searched in a single application.

Two-way audio and audio alarm

Two-way audio allows remote users to listen in on an area and communicate messages to visitors or intruders via an external loudspeaker (not included). Audio detection can be used to generate an alarm if needed.

Tamper and motion detection

A wide range of configuration options is available for alarms signaling camera tampering. A built-in algorithm for detecting movement in the video can also be used for alarm signaling.

Wide system compatibility

The latest Open Network Video Interface Forum (ONVIF) standard ensures compatibility with other surveillance products. The NBC-255-P IP camera is ONVIF-ready. This will contribute to a reduction in future upgrade or migration costs.

Power-over-Ethernet

Power for the camera can be supplied via a Power-over-Ethernet (IEEE 802.3af) compliant network cable connection. With this configuration, only a single cable connection is required to view, power, and control the camera.

Certifications and Approvals

Safety	EU: EN 60950-1: 2006, Reference IEC 60950-1:2005
	US: UL 60950-1: 1st edition dated October 31, 2007
	Canada: CAN/CSA-C22.2 NO. 60950-1-03
EMC	EN 50130-4:1995 + A1:1998 + A2:2003
	FCC Part15 Subpart B, Class B
	EMC directive 2004/108/EC
	EN 55022 class B
	EN 61000-3-2 :2006
	EN 61000-3-3 : 1995+A1 :2001+A2 :2005
	EN 55024
	AS/NZS CISPR 22 (equal to CISPR 22)
	ICES-003 Class B
	EN 50121-4:2006
Product Certifications	CE, FCC, UL, cUL, C-tick, CB, VCCI, KCC
Power supply	CE, UL, cUL, PSE, CCC

Installation/Configuration Notes

Connections

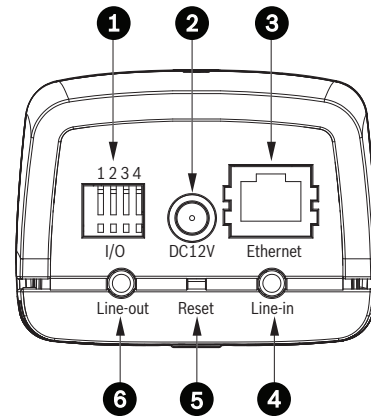

1	I/O
2	Power 12 VDC
3	Ethernet RJ45
4	Audio Line-in
5	Reset
6	Audio Line-out

Dimensions

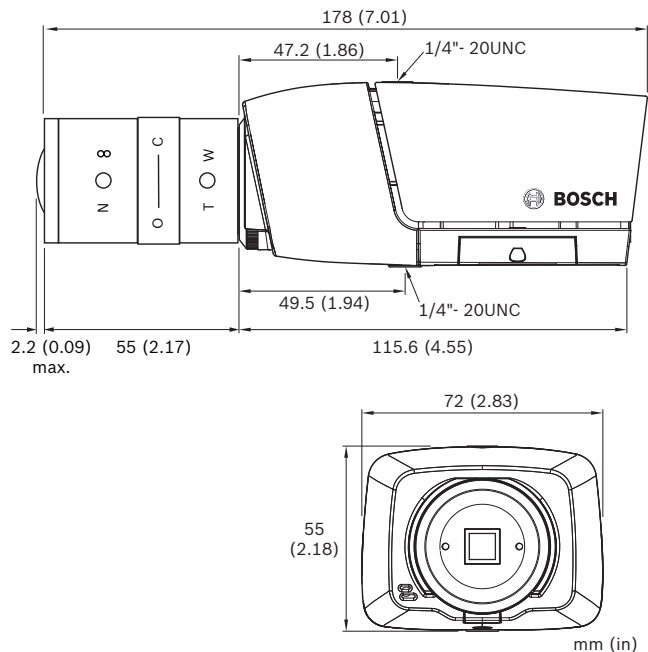

Parts Included

Quantity	Component
1	NBC-255-P IP camera with 2.8 to 10 mm varifocal CS-mount lens
1	Quick Installation Guide
1	CD ROM with BVIP Lite Suite and documentation
1	Camera mount kit
1	SD card (warranty provided by card manufacturer)
1	Universal power supply with US, EU and UK plug

Technical Specifications

Power

Input voltage	+12 VDC or Power-over-Ethernet
Power consumption	3.36 W (max)

Video

Sensor type	¼-inch CMOS
Sensor pixels	640 x 480
Sensitivity	1.0 lux at F1.4
Video resolution	VGA, QVGA
Video compression	H.264 MP (Main Profile); H.264 BP+ (Baseline Profile Plus); M-JPEG
Frame rate	30/25 fps: all resolutions, dual stream

Lens

Lens type	Varifocal 2.8 to 10 mm, F1.4 to close
Lens mount	CS mount

Connection

Alarm input	+9 to 30 VDC
Relay out	24 VAC/VDC, 1 A

Audio

Audio input	Built-in microphone Line in jack connector
Audio output	Line out jack connector
Audio communication	Two-way, full duplex
Audio compression	G.711

Local Storage

SD card slot	Supports up to 32 GB SD/SDHC card
Recording	Continuous recording, ring recording, alarm/events/schedule recording

Software Control

Unit configuration	Via web browser or PC surveillance software
--------------------	---

Network

Protocols	HTTP, HTTPS, SSL, TCP, UDP, ICMP, RTSP, RTP, RTCP, IGMPv2/v3, SMTP, POP3, FTP, DHCP client, ARP, DNS, DDNS, NTP, SNMP
Ethernet	10/100 Base-T, auto-sensing, half/full duplex, RJ45
PoE	IEEE 802.3af compliant

Mechanical

Dimensions with lens (H x W x D)	55 x 72 x 178 mm (2.17 x 2.83 x 7.01 in.)
Weight (with lens)	Approx. 245 g (0.54 lb)
Mounting	¼-inch mounting socket on top and bottom

Environmental

Operating temperature Camera	0 °C to +50 °C (+32 °F to +122 °F)
Operating temperature Universal Power Supply Unit	0 °C to +40 °C (+32 °F to +104 °F)
Storage temperature	-20 °C to +70 °C (-4 °F to +158 °F)
Humidity	10% to 80% relative humidity (non condensing)

Ordering Information

NBC-255-P IP Camera	NBC-255-P
IP Camera System including varifocal lens, mount and power supply	

Accessories

LTC 9348/00 Series Indoor Dome Housings	LTC9348/00
for cameras/lens to 216 mm (8.5 in), ceiling mount, tinted, metal backbox	

UHI-SBG-0 Series Indoor Housing	UHI-SBG-0
For camera/lens lengths up to 210 mm (8.2 in.)	

Software Options

MVC-FAPEX	MVC-FAPEX
Archive Player Exporter license	

Americas:
Bosch Security Systems, Inc.
130 Perinton Parkway
Fairport, New York, 14450, USA
Phone: +1 800 289 0096
Fax: +1 585 223 9180
security.sales@us.bosch.com
www.boschsecurity.us

Europe, Middle East, Africa:
Bosch Security Systems B.V.
P.O. Box 80002
5600 JB Eindhoven, The Netherlands
Phone: + 31 40 2577 284
Fax: +31 40 2577 330
emea.securitysystems@bosch.com
www.boschsecurity.com

Asia-Pacific:
Robert Bosch (SEA) Pte Ltd, Security Systems
38C Jalan Pemimpin
Singapore 577180
Phone: +65 6319 3453
Fax: +65 6319 3499
apr.securitysystems@bosch.com
www.boschsecurity.com

Represented by