

# UHO Series Outdoor Camera Housing

www.boschsecurity.com



**BOSCH**  
Invented for life



- ▶ Protects camera/lens combinations up to 262 mm (10.32 inch) length
- ▶ Hinged side opening for easy installation and camera setup
- ▶ IP66, NEMA-4X enclosure rating
- ▶ Strong aluminum construction
- ▶ Sunshield included

The UHO series housings are smartly styled housings, for outdoor use. These housings are both cost-competitive and installer-friendly. Models are available for use with 24 VAC, 115 VAC, and 230 VAC cameras, to fit a wide range of applications.

## Functions

### Easy installation

The unique, hinged, side-opening design provides easy installation of all camera/lens combinations, and allows access to most camera and lens controls when the housing is mounted. Power, video, and lens control cabling can be routed through liquid-tight fittings in the bottom rear of the housing, or for even better cable management, via the feed-through entry holes in the base. Mounting holes in the base permit installation to a wide range of pan/tilts, adjustable heads, and various camera mount brackets.

### Flexible

External 4-pin and BNC connectors for power and video, located in the rear end cap, are also available on 24 VAC and 230 VAC models. These aluminum-constructed housings are available with a factory-installed heater and blower. The heater maintains the internal temperature of the housing in cold temperature conditions as low as -40 °C (-40 °F). In combination with a permanent low-power window

defroster and a continuous-duty blower, the unit minimizes fogging in high humidity locations, and extends the temperature limits. Sunshields are included on all outdoor models.

### Dinion ready

All models support installation of Dinion style cameras with fixed focal, varifocal, or up to a 15x motorized zoom lens.

### Secure

For increased security, the units come with tamper-resistant screws for the locking clasps to prevent illegitimate access to the housing contents.

### Rugged

With a sleek design that meets IP 66 and NEMA-4X enclosure standards, the UHO Series Housings are the optimal solution for protecting your video surveillance equipment from adverse elements.

## Certifications and Approvals

Safety	acc. to EN 60950-1 (CE) acc. to UL 2044-1; CAN/CSA C 22.2 no. 1-98
Immunity	acc. to EN 50130-4 (CE)
Emission	acc. to EN 55022 class B (CE) acc. to EN 61000-3-2 (CE); EN 61000-3-3 (CE) acc. to FCC CFR 47 Part 15, Class B

Region	Certification	
Europe	CE	UHO-HGS
	CE	UHO-HGS-50x

**Installation/Configuration Notes**

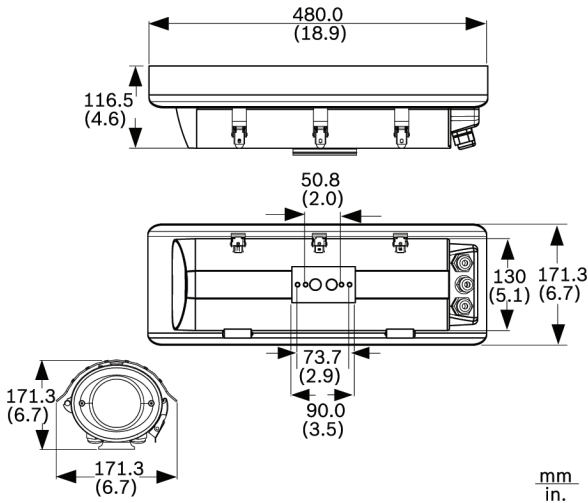

Dimensions in mm for UHO-HGS-10, UHO-HBGS-10, UHO-HGS-50, UHO-HBGS-50 and UHO-HBGS-60 housings outdoor units

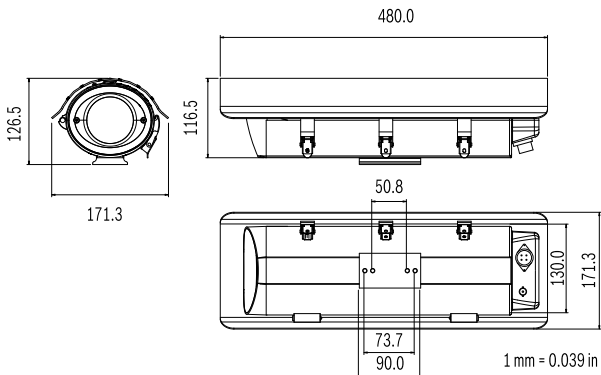

Dimensions in mm for UHO-HBPS-10, UHO-HPS-50 and UHO-HBPS-50 housings outdoor units

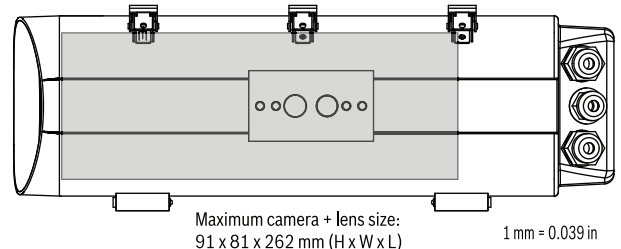
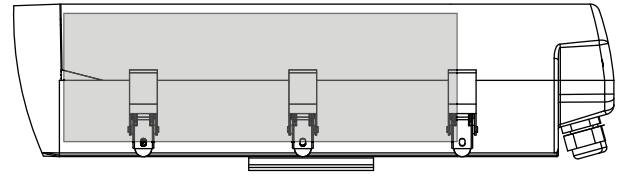

Dimensions in mm for all models, maximum internal usable space available (based on camera/lens size)

**Notice**  
Allowance is provided for wiring and connector space requirements

**Technical Specifications**

**Electrical/Mechanical**

Rear fitting	1x
cable diameter	4.0 to 7.0 mm (0.16 to 0.28 in)
models	UHO-HGS-10, UHO-HBGS-10, UHO-HGS-50, UHO-HBGS-50, UHO-HBGS-60
Rear fittings	2x
cable diameter	6.5 to 10.5 mm (0.26 to 0.42 in)
models	UHO-HGS-10, UHO-HBGS-10, UHO-HGS-50, UHO-HBGS-50, UHO-HBGS-60
Bottom feeds	2x
cable diameter	4.0 to 7.0 mm (0.16 to 0.28 in)
models	UHO-HGS-10, UHO-HBGS-10, UHO-HGS-50, UHO-HBGS-50, UHO-HBGS-60
Rear connector	1x
type	4-pin (power)
models	UHO-HBPS-10, UHO-HPS-50, UHO-HBPS-50
Rear connector	1x
type	BNC (video)
models	UHO-HBPS-10, UHO-HPS-50, UHO-HBPS-50
Window	3 mm (0.12 in) glass
Locking clasps	Tamper-resistant screws provided

Camera power ratings	10 model: 24 VAC, 50/60 Hz, 2 A 50 model: 230 VAC, 50 Hz, 0.21 A 60 model: 120 VAC, 60 Hz, 0.4 A
Camera mounting	Removable camera/lens tray, mounted with two screws
Max camera + lens size (H x W x L)	91 x 81 x 262 mm (3.6 x 3.2 x 10.3 in)
Construction	Aluminum casing, neoprene gaskets, all stainless steel hardware
Dimensions	See drawings
Weight	
UHO-HBG-10,	3.1 kg (6.8 lb)
UHO-HBG-50,	3.1 kg (6.8 lb)
UHO-HPS-50	3.1 kg (6.8 lb)
all others	3.2 kg (7.1 lb)
Mounting	2 x pair of tapped holes
thread	1/4-20
inner pair	50.8 mm (2.0 in) center spread
outer pair	73.7 mm (2.9 in) center spread
Color	Gray

**Environmental**

Operating temperature (with fixed lens)*	External: -40 °C to +50 °C (-40 °F to +122 °F) Internal: -20 °C to +55 °C (-4 °F to +131 °F)
Operating temperature (with zoom lens)*	External: -30 °C to +50 °C (-22 °F to +122 °F) Internal: -10 °C to +55 °C (+14 °F to +131 °F)
Enclosure protection	IP66, NEMA-4X

\* With heater/blower accessories installed

**Ordering Information**

**UHO-HGS-10 Outdoor Housing**

for camera/lens up to 262 mm (10.3 in.), 24 VAC, 50/60 Hz, heater, sunshield, feed-through cabling  
Order number **UHO-HGS-10**

**UHO-HBGS-10 Outdoor Housing**

for camera/lens up to 262 mm (10.3 in.), 24 VAC, 50/60 Hz, heater, blower, sunshield, feed-through cabling  
Order number **UHO-HBGS-10**

**UHO-HBPS-10 Outdoor Housing**

for camera/lens up to 262 mm (10.3 in.), 24 VAC, 50/60 Hz, heater, blower, sunshield, outside BNC connector and outside power connector  
Order number **UHO-HBPS-10**

**UHO-HGS-50 Outdoor Housing**

for camera/lens up to 262 mm (10.3 in.), 230 VAC, 50/60 Hz, heater, sunshield, feed-through cabling  
Order number **UHO-HGS-50**

**UHO-HBGS-50 Outdoor Housing**

for camera/lens up to 262 mm (10.3 in.), 230 VAC, 50/60 Hz, heater, blower, sunshield, feed-through cabling  
Order number **UHO-HBGS-50**

**UHO-HPS-50 Outdoor Housing**

for camera/lens up to 262 mm (10.3 in.), 230 VAC, 50/60 Hz, heater, sunshield, outside BNC connector and outside power connector  
Order number **UHO-HPS-50**

**UHO-HBPS-50 Outdoor Housing**

for camera/lens up to 262 mm (10.3 in.), 230 VAC, 50/60 Hz, heater, blower, sunshield, outside BNC connector and outside power connector  
Order number **UHO-HBPS-50**

**UHO-HBGS-60 Outdoor Housing**

for camera/lens up to 262 mm (10.3 in.), 120 VAC, 60 Hz, heater, blower, sunshield, feed-through cabling  
Order number **UHO-HBGS-60**

**Accessories**

**LTC 9215/00 Mount**

Wall mount for LTC/HSG 948x, HSG9583 and UHI/UHO housings  
Order number **LTC9215/00**

**LTC 9215/00S Mount**

Short wall mount for LTC/HSG 948x, HSG9583 and UHI/UHO housings  
Order number **LTC9215/00S**

**LTC 9219/01 J-Mount**

Feed-through J- mount for LTC/HSG 948x, HSG9583 and UHI/UHO housings  
Order number **LTC9219/01**

**HAC-TAMP01 Tamper Switch**

Tamper switch kit for HSG and UHI/UHO series enclosures  
Order number **HAC-TAMP01**

**Represented by:**

**Americas:**

Bosch Security Systems, Inc.  
130 Perinton Parkway  
Fairport, New York, 14450, USA  
Phone: +1 800 289 0096  
Fax: +1 585 223 9180  
security.sales@us.bosch.com  
www.boschsecurity.us

**Europe, Middle East, Africa:**

Bosch Security Systems B.V.  
P.O. Box 80002  
5617 BA Eindhoven, The Netherlands  
Phone: + 31 40 2577 284  
Fax: +31 40 2577 330  
emea.securitysystems@bosch.com  
www.boschsecurity.com

**Asia-Pacific:**

Robert Bosch (SEA) Pte Ltd, Security  
Systems  
11 Bishan Street 21  
Singapore 573943  
Phone: +65 6571 2808  
Fax: +65 6571 2699  
apr.securitysystems@bosch.com  
www.boschsecurity.asia

**China:**

Bosch (Shanghai) Security Systems Ltd.  
201 Building, No. 333 Fuquan Road  
North IBP  
Changning District, Shanghai  
200335 China  
Phone +86 21 22181111  
Fax: +86 21 22182398  
www.boschsecurity.com.cn

**America Latina:**

Robert Bosch Ltda Security Systems Division  
Via Anhanguera, Km 98  
CEP 13065-900  
Campinas, Sao Paulo, Brazil  
Phone: +55 19 2103 2860  
Fax: +55 19 2103 2862  
al.securitysystems@bosch.com  
www.boschsecurity.com